

Do the following problems as indicated.

Find the coordinates of the labeled points.

1)

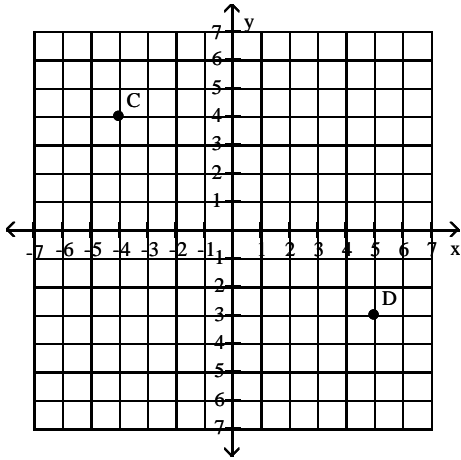

2)

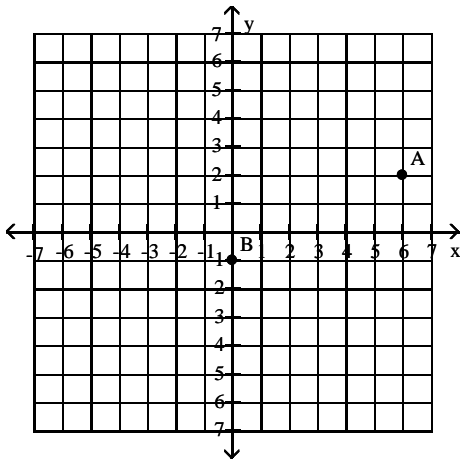

Graph the linear equation.

3) $2y - 4x = 18$

4) $-3x + y = 0$

5) $5x - y = 3$

6) $y = 3x + 4$

7) $-x + 8y = 5$

8) $y = \frac{1}{5}x - 3$

Graph.

9) $y = 3$

10) $x = -2$

11) $y = \frac{7}{2}$

12) $-3x - 25 = 0$

Write an equation for the graph.

13)

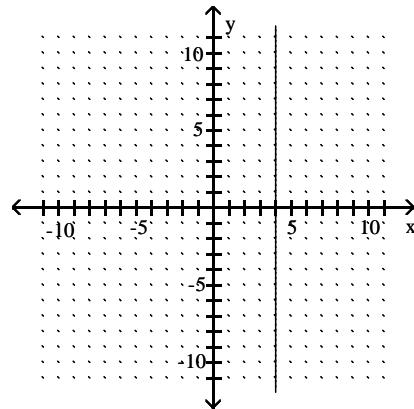

14)

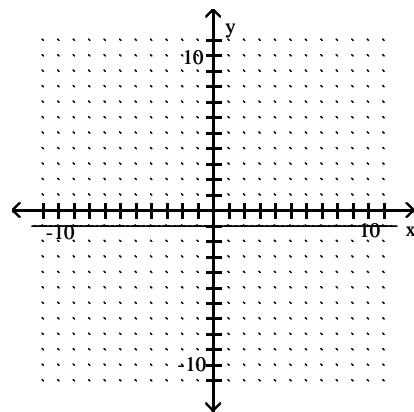

Find the slope of the line going through the pair of points.

15) $(7, -9), (-6, 1)$

16) $(-5, -5), (-5, 6)$

17) $(-2, -3), (5, 2)$

Draw a line that has the given slope and y-intercept.

18) Slope $\frac{1}{2}$; y-intercept (0, 2)

Determine whether the graphs of the equations are parallel lines, perpendicular lines, or neither.

19) $3x - 8y = -18$
 $32x + 12y = -18$

20) $6x + 2y = 8$
 $24x + 8y = 33$

21) $4x - 12y = 13$
 $48x + 12y = 13$

Write an equation of the line with the given slope and y-intercept. Write the final equation in standard form ($Ax + By = C$).

22) $m = -\frac{3}{4}$; (0, 7)

23) $m = \frac{4}{5}$; (0, -2)

Write an equation of the line through the given point with the given slope. Write the final equation in standard form ($Ax + By = C$).

24) (5, 4); $m = 3$

25) (2, 2); $m = -\frac{5}{7}$

Write an equation of the line through the two given points. Write the final equation in standard form ($Ax + By = C$).

26) (-7, -5) and (9, 6)

27) (-10, -9) and (4, -9)

Find an equation of the line. Write the equation in standard form ($Ax + By = C$).

28) Through (9, 1); parallel to $5x + 9y = -27$

29) Through (-2, -5); perpendicular to $3x + 5y = -17$

Find an equation of the line.

30) Perpendicular to $y = 9$, through (-7, 3)

31) Parallel to $y = -6$, through (4, 3)

32) Parallel to $x = 9$, through (-4, -5)

33) Perpendicular to $x = 6$, through (-6, 5)

Graph the linear inequality.

34) $5x + y \leq 3$

35) $-2x - 4y \leq 8$

36) $2x + 3y \geq -6$

37) $x + y < -3$

38) $y \geq 4x$

39) $y < -3$

40) $x \geq 4$

41) $y < -2x + 1$

Without solving, determine whether the given system has one solution, no solution or infinite solution.

42) $4x + y = 14$
 $16x + 4y = 56$

43) $x = -y$
 $y + x = 6$

44) $-2x + 3y = 19$
 $3x + 2y = 17$

45) $3x + 2y = 5$
 $-6x - 4y = 5$

Solve each system.

$$\begin{aligned} 46) \quad x + y &= -4 \\ y &= -3x + 2 \end{aligned}$$

$$\begin{aligned} 47) \quad -5x - 4y &= -48 \\ -3x + 2y &= 2 \end{aligned}$$

$$\begin{aligned} 48) \quad x + 6y &= 50 \\ -5x + 5y &= -5 \end{aligned}$$

Solve each system.

$$\begin{aligned} 49) \quad x + 3y &= -10 \\ -6x + 2y &= -20 \end{aligned}$$

$$\begin{aligned} 50) \quad x + y &= 2 \\ x + y &= -9 \end{aligned}$$

$$\begin{aligned} 51) \quad x + y &= 6 \\ 6x + 6y &= 36 \end{aligned}$$

$$\begin{aligned} 52) \quad -x + 5y &= -6 \\ 3x - 5y &= -2 \end{aligned}$$

$$\begin{aligned} 53) \quad 8x - 5y &= -10 \\ -2x + 5y &= -20 \end{aligned}$$

$$\begin{aligned} 54) \quad 3x + 5y &= -5 \\ -6x - 10y &= -10 \end{aligned}$$

$$\begin{aligned} 55) \quad -6x - 2y &= -5 \\ -12x - 4y &= -10 \end{aligned}$$

$$\begin{aligned} 56) \quad 8x + 7y &= -16 \\ 6x - 3y &= -12 \end{aligned}$$

Solve the problem.

57) Helen Weller invested \$15,000 in an account that pays 12% simple interest. How much additional money must be invested in an account that pays 15% simple interest so that the total interest is equal to the interest on the two investments at the rate of 13%?

58) Two angles are supplementary, and one is 40° more than three times the other. Find the smaller angle.

59) Mrs. Boyd has a desk full of quarters and nickels. If she has a total of 26 coins with a total face value of \$5.10, how many of the coins are nickels?

60) Ron and Kathy are ticket-sellers at their class play, Ron handling student tickets that sell for \$2.00 each and Kathy selling adult tickets for \$5.50 each. If their total income for 30 tickets was \$105.50, how many did Ron sell?

61) Roberto invested some money at 7%, and then invested \$2000 more than twice this amount at 11%. His total annual income from the two investments was \$3990. How much was invested at 11%?

62) How many liters of a 60% alcohol solution must be mixed with 50 liters of a 90% solution to get a 70% solution?

63) In a chemistry class, 6 liters of a 4% silver iodide solution must be mixed with a 10% solution to get a 6% solution. How many liters of the 10% solution are needed?

64) A merchant has coffee worth \$20 a pound that she wishes to mix with 90 pounds of coffee worth \$80 a pound to get a mixture that can be sold for \$70 a pound. How many pounds of the \$20 coffee should be used?

65) A cruise boat travels 48 miles downstream in 3 hours and returns upstream in 6 hours. Find the rate of the stream.

66) An airplane travels 600 miles against the wind in 5 hours, and makes the return trip with the same wind in 2 hours. Find the speed of the wind.

Answer Key

Testname: 114EXAM1REVIEW

1) C(-4, 4); D(5, -3)

2) A(6, 2); B(0, -1)

3)

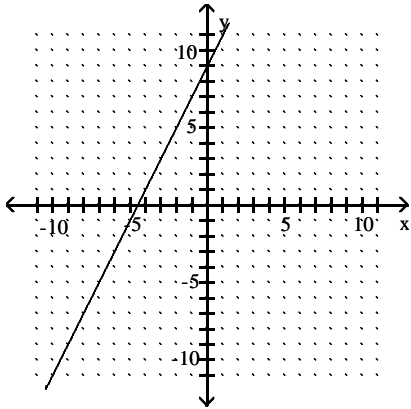

4)

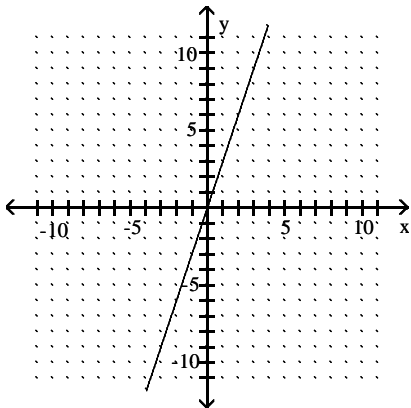

5)

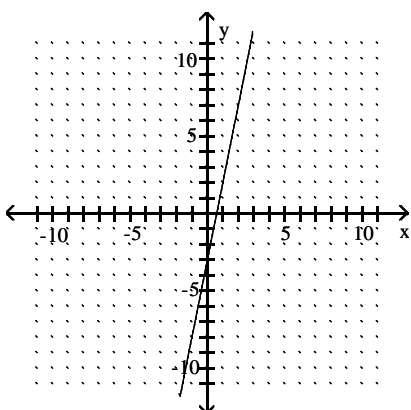

6)

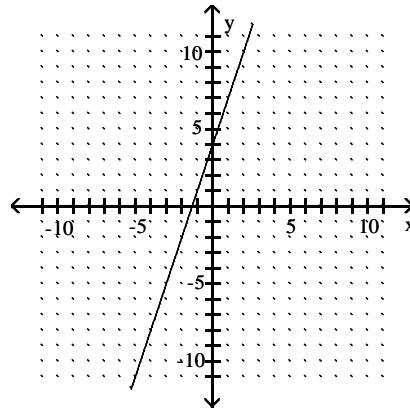

7)

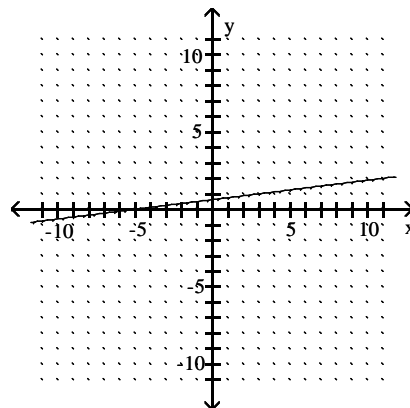

8)

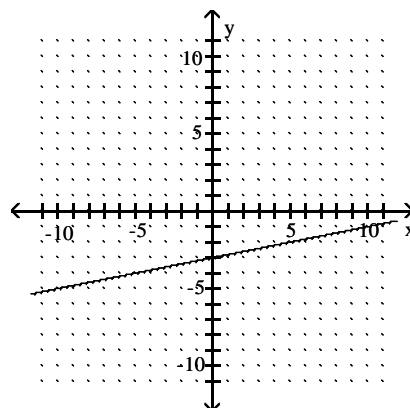

Answer Key

Testname: 114EXAM1REVIEW

9)

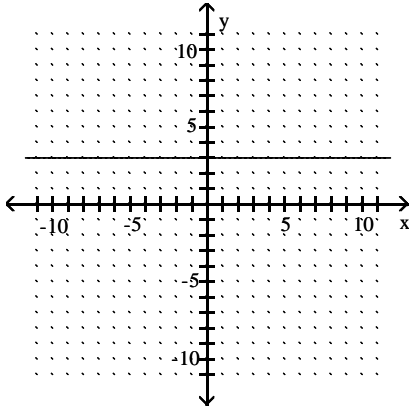

10)

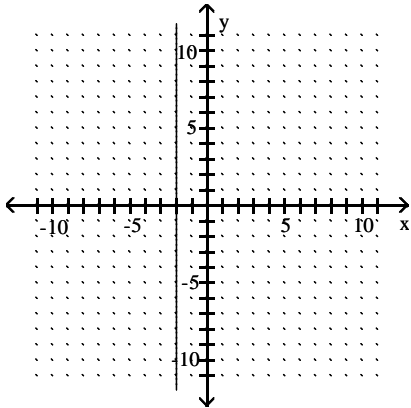

11)

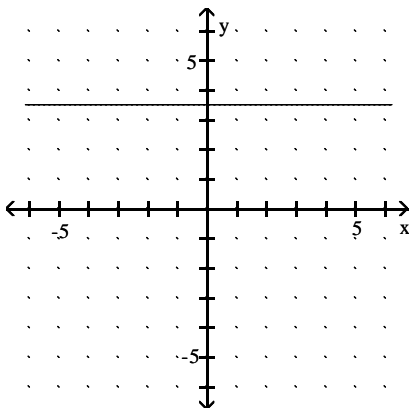

12)

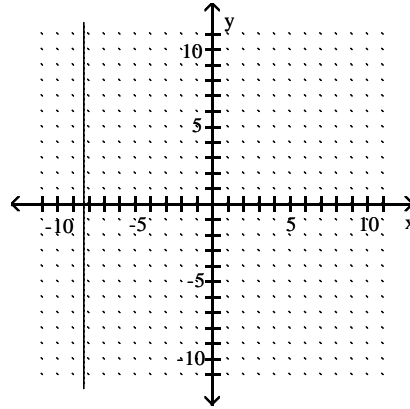

13) $x = 4$

14) $y = -1$

15) $-\frac{10}{13}$

16) Undefined

17) $\frac{5}{7}$

18)

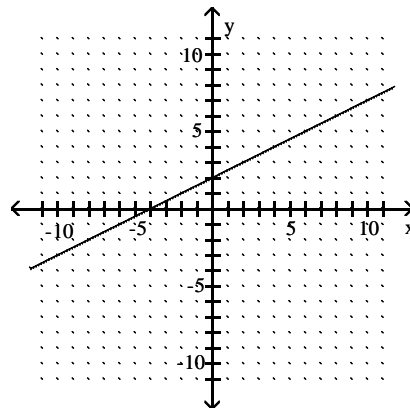

19) Perpendicular

20) Parallel

21) Neither

22) $3x + 4y = 28$

23) $4x - 5y = 10$

24) $3x - y = 11$

25) $5x + 7y = 24$

26) $11x - 16y = 3$

27) $y = -9$

28) $f(x) = -\frac{5}{9}x + 6$

29) $f(x) = \frac{5}{3}x - \frac{5}{3}$

30) $x = -7$

31) $y = 3$

32) $x = -4$

Answer Key

Testname: 114EXAM1REVIEW

33) $y = 5$

34)

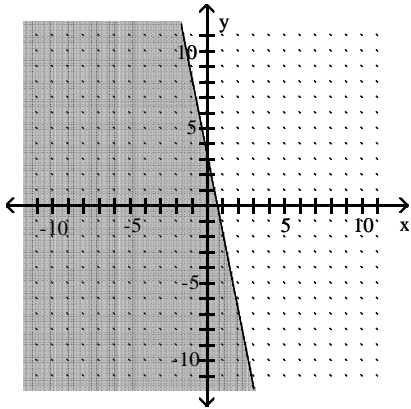

35)

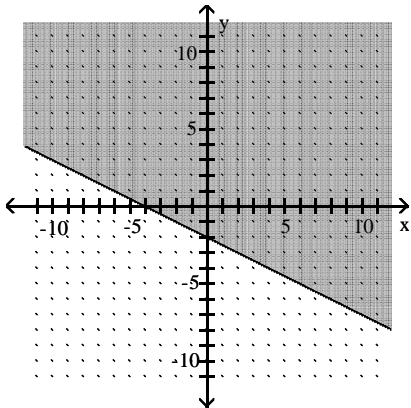

36)

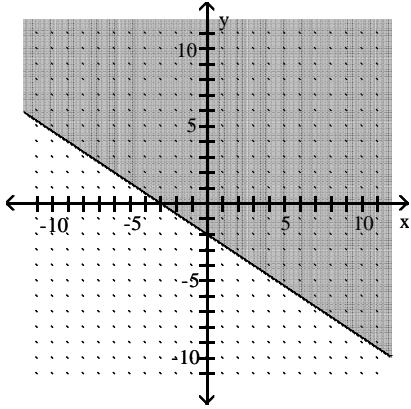

37)

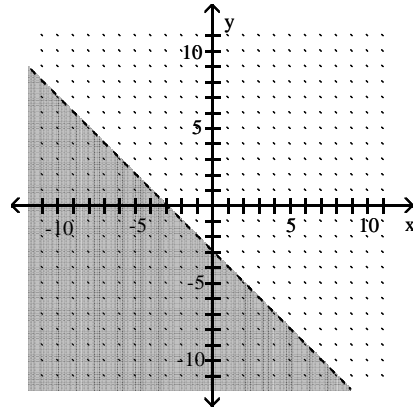

38)

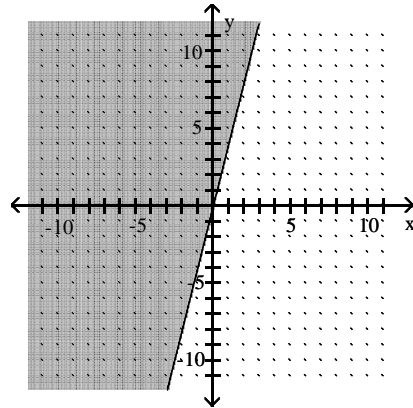

39)

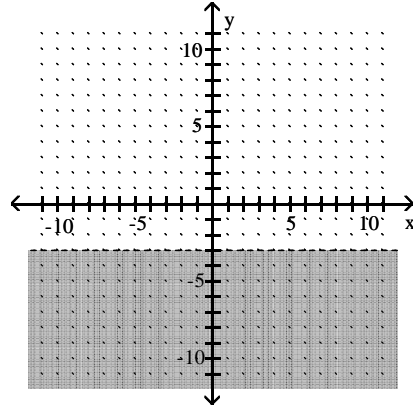

Answer Key

Testname: 114EXAM1REVIEW

40)

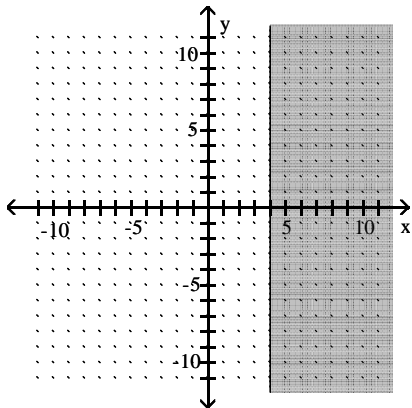

66) 90 mph

41)

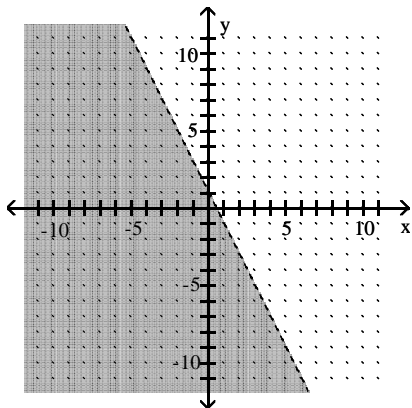

- 42) Infinite number of solutions
- 43) No solution
- 44) one solution
- 45) No solution
- 46) (3, -7)
- 47) (4, 7)
- 48) (8, 7)
- 49) (2, -4)
- 50) No solution
- 51) Infinite number of solutions
- 52) (-4, -2)
- 53) (-5, -6)
- 54) No solution
- 55) Infinite number of solutions
- 56) (-2, 0)
- 57) \$7500
- 58) 35°
- 59) 7 nickels
- 60) 17 tickets
- 61) \$28,000
- 62) 100 L
- 63) 3.0 L
- 64) 18 lb
- 65) 4 mph